



Precision, Adjustable Shunt Regulator (600mV Reference)



FEATURES

- 600mV low voltage reference
- 35ppm low temperature coefficient
- ±6mV initial accuracy
- High PSRR: 45dB at 300kHz
- Better line regulation: 1mV (V_{IN} from 2.2V to 18V)
- Low supply current: 90µA
- Open drain output
- Directly drives optocouplers
- Industrial temperature range of -40°C to 85°C
- RoHS-compliant 5-lead TSOT23 package

APPLICATION

- SMPS control loop
- Low temperature coefficient voltage reference
- Power management
- Replaces zener diodes
- Isolated DC-to-DC converters
- Network, telecom and cellular base station
- Adjustable voltage reference

DESCRIPTION

The CAT102 is a low-voltage reference and amplifier. Designed for the control loop of low-voltage power supplies, the reference voltage has been designed for 600mV. Over a junction temperature from -40°C to 105°C, the reference voltage is within 8mV of the nominal 600mV. In addition, the error amplifier output and the supply voltage pin (IN) are on separate pins.

Power supply rejection is a high 45dB at 300kHz. The output, OUT, can sink 20mA at a maximum saturation voltage of 250mV.

When combined with an optocoupler, the CAT102 can be used as an error amplifier that controls the feedback loop in isolated low-output voltage switching power supplies.

For Ordering Information details, see page 7.

FUNCTIONAL DIAGRAM

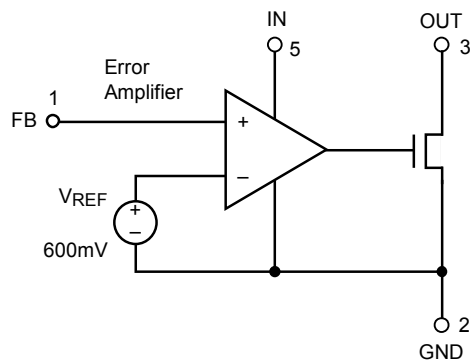

PIN CONFIGURATION

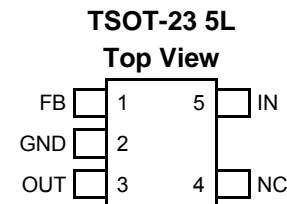

PIN DESCRIPTION

Pin Name	Function
FB	Inverting input to error amplifier
GND	Ground
OUT	Output of error amplifier. Source & sink current capability is 20mA.
NC	No connection
IN	Positive supply

ABSOLUTE MAXIMUM RATINGS⁽¹⁾

Parameters	Ratings	Units
V _{IN} Voltage	20	V
OUT Voltage	20	V
FB Voltage	20	V
V _{IN} , OUT, FB Current	50	mA
Operating Junction Temperature (10s)	150	°C
Lead Soldering Temperature (10s)	260	°C
Storage Temperature Range	-65 to +150	°C

ELECTRICAL CHARACTERISTICS

Electrical characteristics are guaranteed over the full operating temperature range of -40°C to +85°C with a junction temperature from -40°C to +105°C unless otherwise specified. Ambient temperature must be de-rated based upon power dissipation and package thermal characteristics.¹ Unless otherwise stated, test conditions are V_{IN} = 3V, FB = OUT, I_{OUT} = 1mA.

Symbol	Parameter	Conditions	Min	Typ	Max	Units
V _{IN}	Supply Voltage Range		2.2		18	V
I _{IN}	Quiescent Supply Current	V _{OUT} = 1V		90	500	µA
V _{FB}	FB Threshold Reference Voltage	T _J = 25° C	594	600	606	mV
		-40°C < T _J < 105°C	592		608	
	Line Regulation	V _{IN} = 2.2V to V _{IN} = 18V		0.5	1	mV
	Load Regulation	I _{OUT} = 1mA to 10mA		3	8	mV
T _{CREF}	Reference Temperature Deviation	-40°C < T _J < 105°C		35	50	ppm/°C
I _{FB}	FB Input Current		-500		500	nA
PSRR	Reference Power Supply Rejection	Frequency = 300kHz	35	65		dB
A _V	Error Amplifier Open Loop Gain	I _{OUT} = 2mA, V _{OUT} = 1V	60	80		dB
BW	Unity Gain Frequency	I _{OUT} = 2mA, V _{OUT} = 1V	1	2		MHz
V _{OUT}	Output Saturation voltage	I _{OUT} = 20mA, V _{FB} = HIGH		130	250	mV
TRANSC	Output Transconductance	I _{OUT} = 1mA to 20mA		2.5		mA/mV
I _{LEAK}	Output Leakage Current	V _{OUT} = 16V, V _{FB} = 0		20	400	nA
I _{OUT(MAX)}	Maximum Output Current	V _{OUT} = 0.3V	20			mA

Notes:

- (1) These are stress ratings only and functional operation is not implied. Exposure to absolute maximum ratings for prolonged time periods may affect device reliability. All voltages are with respect to ground.
- (2) Thermal Characteristics (Θ_{JA}) of TSOT-23 5-lead: 255°C/W

TYPICAL PERFORMANCE CHARACTERISTICS

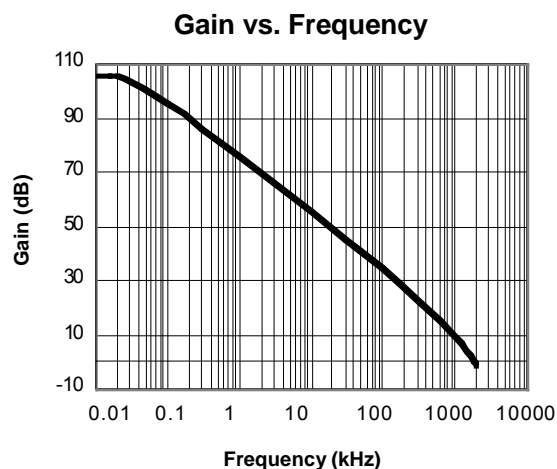
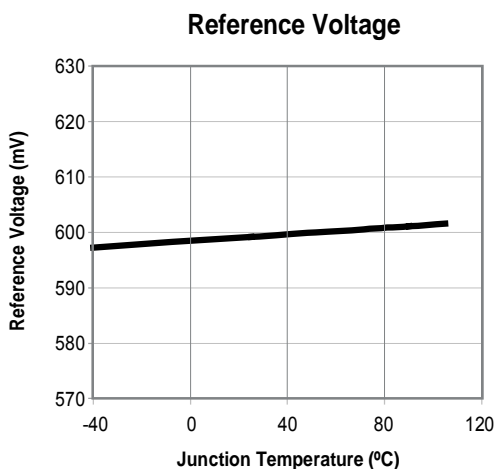
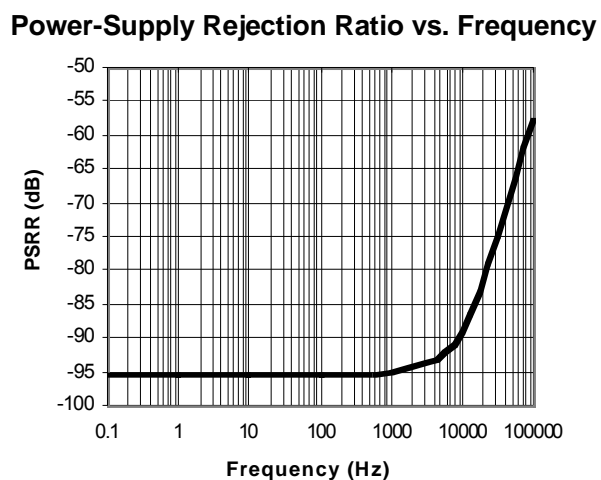
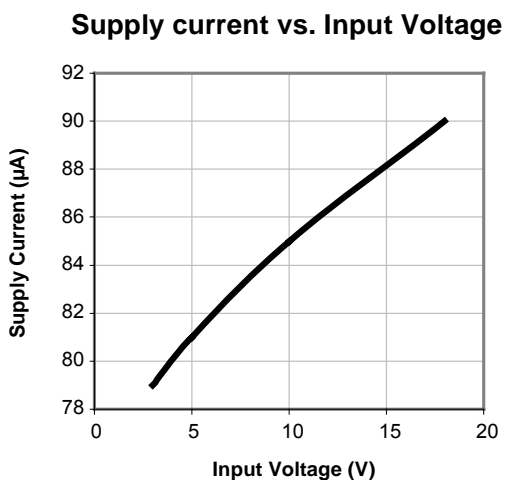
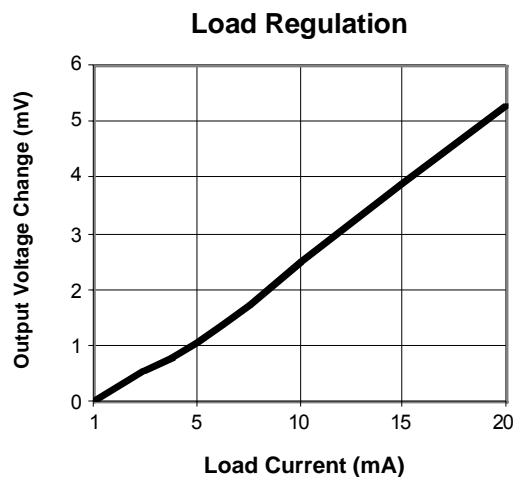
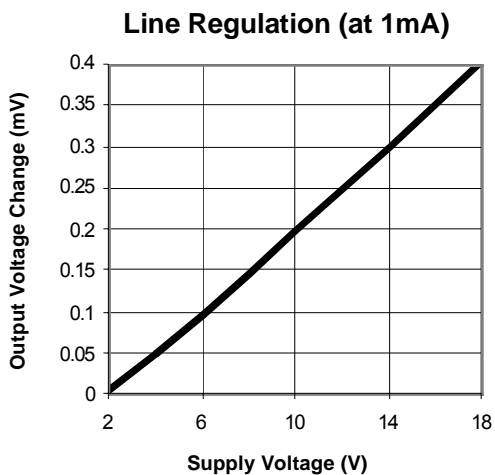

APPLICATIONS INFORMATION

The CAT102 adjustable shunt regulator features isolated supply inputs and outputs, ideal for isolated power-supply applications using an optocoupler in the feedback path. The CAT102 sinks 20mA with V_{OUT} at 0.3V. The wide input supply range allows the device to operate from 2.2V to 18V. The CAT102 compares the FB input to a precision 600mV reference. If the FB input is low, the OUT pin sinks no current. If FB rises above 600mV, the OUT pin sinks up to 20mA.

The current limit can be adjusted by using a resistor R3 connected between the IN and OUT pins. For example, a 3.3V supply V_{IN} is associated with $R_3 = 135\Omega$, and a 10V supply works best with $R_3 = 470\Omega$. The CAT102 shunt regulator is limited to low-current applications with the OUT pin capable of sinking up to 20mA max.

Figure 1 shows the CAT102 configured as a shunt regulator. To generate an output voltage of 0.6V, the FB pin has to be directly connected to the OUT pin. A 1.0µF capacitor from OUT to GND is recommended when the output voltage is 0.6V. A resistor-divider connected from OUT to GND is used to produce a higher output voltage as set by the following equation:

$$V_{OUT} = (1 + R_1/R_2) \times 0.6V$$

Figure 1. Application circuits for 0.6V output and 1.2V output voltages

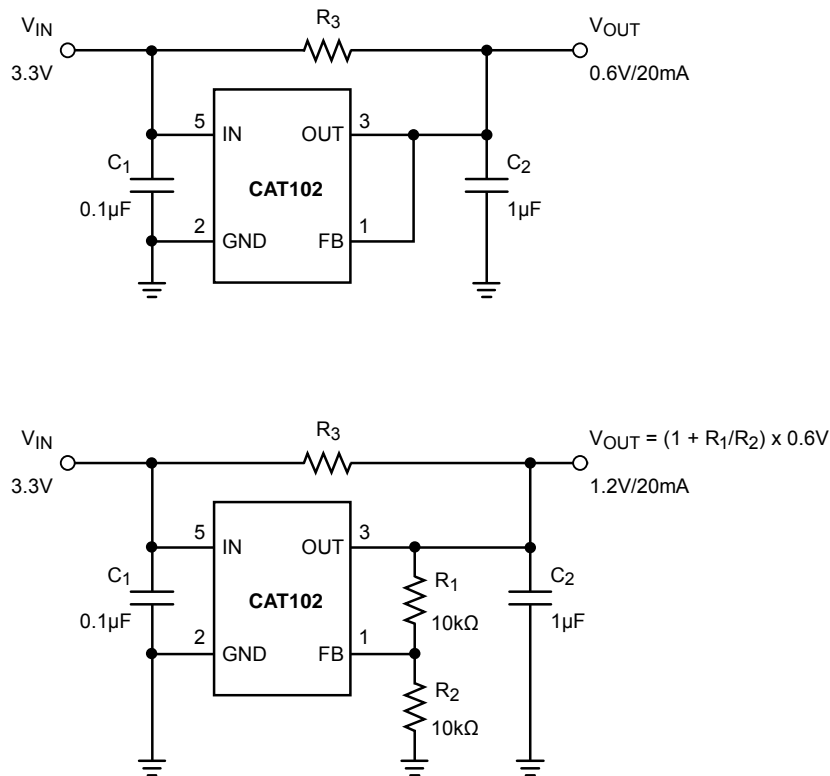

TYPICAL APPLICATION

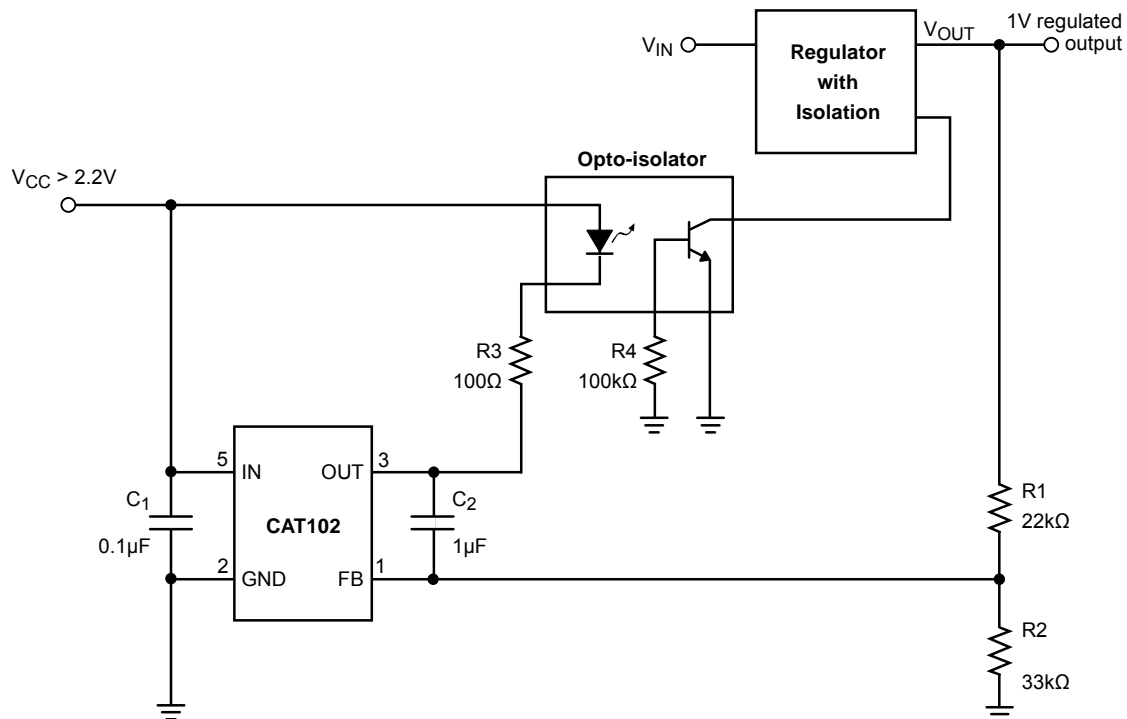
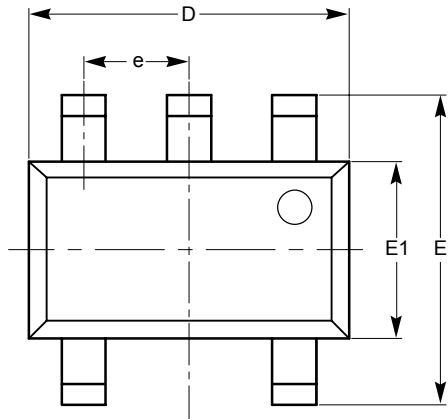

Figure 2. Opto-Feedback Application Circuit

In order to allow proper operation of the optocoupler and the CAT102, the supply voltage V_{CC} must be greater than 2.2V.

PACKAGE OUTLINE DRAWING

TSOT-23 5-Lead (TD)



TOP VIEW

SYMBOL	MIN	NOM	MAX
A			1.00
A1	0.01	0.05	0.10
A2	0.80	0.87	0.90
b	0.30		0.45
c	0.12	0.15	0.20
D	2.90 BSC		
E	2.80 BSC		
E1	1.60 BSC		
e	0.95 TYP		
L	0.30	0.40	0.50
L1	0.60 REF		
L2	0.25 BSC		
θ	0°		8°

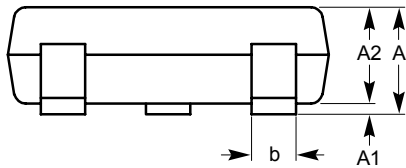

SIDE VIEW

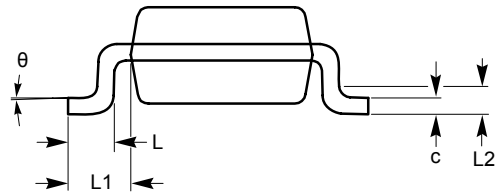

END VIEW

For current Tape and Reel information, download the PDF file from:
<http://www.catsemi.com/documents/tapeandreel.pdf>.

Notes:

- (1) All dimensions in millimeters. Angles in degrees.
- (2) Complies with JEDEC MO-193.

EXAMPLE OF ORDERING INFORMATION

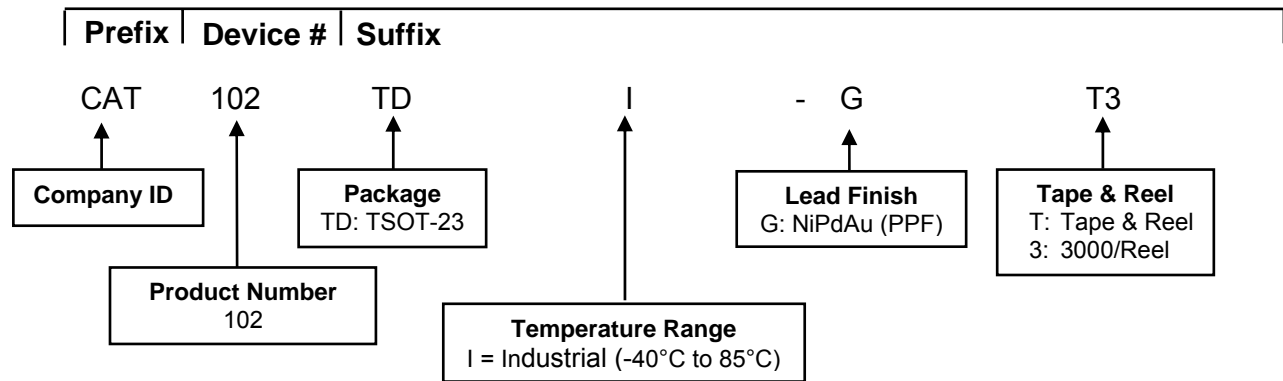

ORDERING PART NUMBER
CAT102TDI-G

Notes:

- (1) All packages are RoHS-compliant (Lead-free, Halogen-free)
- (2) The device used in the above example is a CAT102TDI-GT3 (TSOT-23, Industrial Temperature, NiPdAu, Tape & Reel)

REVISION HISTORY

Date	Rev.	Description
29-Jan-07	M	Added Ordering Information
16-Jun-07	N	Changed package from SOT-23 to TSOT-23 Updated Features Updated Functional Diagram Updated Electrical Characteristics Updated Typical Performance Characteristics Changed termination from SnPb to NiPdAu Added MD- to document Number
19-Nov-08	O	Change logo and fine print to ON Semiconductor

ON Semiconductor and  are registered trademarks of Semiconductor Components Industries, LLC (SCILLC). SCILLC reserves the right to make changes without further notice to any products herein. SCILLC makes no warranty, representation or guarantee regarding the suitability of its products for any particular purpose, nor does SCILLC assume any liability arising out of the application or use of any product or circuit, and specifically disclaims any and all liability, including without limitation special, consequential or incidental damages. "Typical" parameters which may be provided in SCILLC data sheets and/or specifications can and do vary in different applications and actual performance may vary over time. All operating parameters, including "Typicals" must be validated for each customer application by customer's technical experts. SCILLC does not convey any license under its patent rights nor the rights of others. SCILLC products are not designed, intended, or authorized for use as components in systems intended for surgical implant into the body, or other applications intended to support or sustain life, or for any other application in which the failure of the SCILLC product could create a situation where personal injury or death may occur. Should Buyer purchase or use SCILLC products for any such unintended or unauthorized application, Buyer shall indemnify and hold SCILLC and its officers, employees, subsidiaries, affiliates, and distributors harmless against all claims, costs, damages, and expenses, and reasonable attorney fees arising out of, directly or indirectly, any claim of personal injury or death associated with such unintended or unauthorized use, even if such claim alleges that SCILLC was negligent regarding the design or manufacture of the part. SCILLC is an Equal Opportunity/Affirmative Action Employer. This literature is subject to all applicable copyright laws and is not for resale in any manner.

PUBLICATION ORDERING INFORMATION

LITERATURE FULFILLMENT:

Literature Distribution Center for ON Semiconductor
P.O. Box 5163, Denver, Colorado 80217 USA
Phone: 303-675-2175 or 800-344-3860 Toll Free USA/Canada
Fax: 303-675-2176 or 800-344-3867 Toll Free USA/Canada
Email: orderlit@onsemi.com

N. American Technical Support: 800-282-9855 Toll Free
USA/Canada
Europe, Middle East and Africa Technical Support:
Phone: 421 33 790 2910
Japan Customer Focus Center:
Phone: 81-3-5773-3850

ON Semiconductor Website: www.onsemi.com
Order Literature: <http://www.onsemi.com/orderlit>
For additional information, please contact your local Sales Representative